



Installation guide

heatcon! system



heatcon! system

Installation guide

Edition: 32 / 2018

Art: 0480000582-1832

We reserve the right to make technical and content changes to this document at all times without prior notice.

EbV assumes no responsibility for any errors or omissions in this document.

All rights to this document and the contained the contained themes and figures are reserved. Reproduction, disclosure to third parties or use of the content, either in whole or in part, is forbidden without the prior written consent of EbV.

Copyright© 2018 EbV - Elektronikbau- und Vertriebs GmbH

All rights reserved

1 Table of contents

1	Table of contents	3
2	Safety	4
2.1	General Information	4
2.2	Structure of the warning instructions.....	4
2.3	Intended use	5
2.4	Personnel qualifications	5
2.5	Safety instructions for operating	6
2.5.1	Hazards due to water temperatures > 60 °C	6
2.6	Warranty conditions	7
3	System description	8
3.1	General Information	8
3.2	System expansion.....	8
3.3	System overview	9
4	Components	10
4.1	heatcon! MMI	10
4.2	heatcon! EC	11
4.3	heatcon! EM	12
4.4	heatcon! RC 130	13
4.5	Single room control heatapp!	14
5	Operation.....	15
5.1	heatcon! MMI	15
5.1.1	Basic display	15
5.1.2	Menu navigation.....	16
5.1.3	Menu overview	18
5.1.4	Configuring the basic display	19
5.1.5	Speed button functions	20
6	Initial operation	30
6.1	Conditions and requirements	30
6.2	Initial operation using the setup wizard.....	30
6.2.1	Assignment of the inputs and outputs.....	31
6.2.2	Setup wizard in heatcon! MMI.....	35
6.2.3	Setup wizard in the Internet browser on a PC/laptop	38
6.2.4	Creating the network connection	38
6.3	Single room control heatapp!	48
7	Attachment	49
7.1	Switching times table	49
7.2	Login data.....	50
8	Index.....	51

2 Safety

2.1 General Information

Any person charged with working on the device or system, must have read and understood this manual, especially the chapter on "Safety".

Instruction may be necessary, dependent on the professional qualifications of the persons in question.

The relevant accident prevention regulations and other generally accepted safety regulations must be complied with.

2.2 Structure of the warning instructions

Explanation of the warning instructions in this manual:

⚠ DANGER

Brief description of the hazard

The signal word **DANGER** indicates a directly threatening hazard.

Non-observation leads to severe injuries or death.

⚠ WARNING

Brief description of the hazard

The signal word **WARNING** indicates a possible hazard.

Non-observation may result in severe injuries or death.

⚠ CAUTION

Brief description of the hazard

The signal word **CAUTION** indicates a possible hazard.

Non-observation can result in slight or moderate injuries.

ATTENTION

Brief description

The signal word **Attention** indicates possible property damage.

Non-observation can lead to damage to the device or plant.

NOTE

The signal word **note** indicates further information about the device or its use.

2.3 Intended use

The device or system is intended solely for the use described in the section "System description", on page 8 with supplied and approved components.

Any other use is classified as an improper use. The manufacturer shall not be liable for any damage resulting from this. The user/operator is solely responsible for the risk.

Observance of the information contained in the operating instructions forms part of the intended use.

Hazards can arise from the system if it is not used as intended.

2.4 Personnel qualifications

The electrical installation, initial operation and servicing of the device may only be performed by qualified electrical technicians who have been authorised by the operator.

The technicians must have read and understood these operating instructions and follow their procedures.

Requirements to be met by a qualified electrical technician:

- Knowledge of general and special safety and accident prevention regulations.
- Knowledge of the relevant electrical regulations (e.g. DIN VDE 0100 Part 600, DIN VDE 0100-722) plus the relevant national regulations.
- Ability to identify risks and avoid possible hazards.

2.5 Safety instructions for operating

2.5.1 Hazards due to water temperatures > 60 °C

During operation, there is a risk of scalding at all heating system hot water outlets in the following cases because of hot water temperatures > 60°C:

- **Automatic anti-legionella system**
If the automatic anti-legionella system is activated, the domestic hot water will automatically be heated up to a temperature of 65 °C in order to kill legionella bacteria in the hot water system on the selected day and at the selected time.
- **Manual mode/ Emission measurement**
In the manual mode / emission measurement mode the domestic hot water can be heated up to the maximum possible boiler temperature because the burner and all pumps are switched on and the valves will be completely opened.
Heating and domestic hot water are not temperature controlled in these modes. These modes are especially used by the emission measurement specialist or by the installer in case the controller is defective.
However, the high water temperatures can be avoided if the boiler thermostat is adjusted to a max. boiler temperature of 60 °C.

Observe the following points to prevent scalding:

- Inform all users of the danger.
- Mix enough cold water or switch the domestic hot water loading pump off manually (if there is a switch at the pump).

2.6 Warranty conditions

Improper use, non-observation of these instructions, use of inadequately qualified personnel and independent changes exclude any liability on the part of the manufacturer for the resulting damage. The manufacturer's warranty becomes void.

ATTENTION

Impairment of device function if incorrect spare parts are used!

If unauthorised parts are used correct functioning is not assured. Use spare parts authorised by customer service.

3 System description

3.1 General Information

The *heatcon!* system is designed exclusively for the control of hot water heating and district heating systems including domestic hot water control. These systems should not exceed a flow temperature of 120 °C.

The *heatcon!* system consists of the following components:

heatcon! EC

The EC base controller is the main control unit and is installed in or on the energy generator.

heatcon! MMI

The MMI is a control unit for connecting to the EbV-system bus for operation of the whole system without an Internet browser.

heatcon! RC 130

The RC room station can be used as a remote-control unit for room groups via the wired h2B bus.

heatcon! EM

The EM expansion module serves as an extension on the inputs and outputs of an EC-Base controller within the system.

heatapp!

Connection and integration to singleroom control *heatapp!* via local ethernet connection (LAN)

heatapp! app

The app is installed on mobile devices such as smartphones or tablets (iOS or Android) and is used to control *heatcon!* systems.

3.2 System expansion

The *heatcon!* system can be expanded with the following components:

- Up to 3 *heatcon! EC* basic controllers.
- Up to 6 *heatcon! EM* expansion modules (maximum of two expansion modules per *heatcon! EC* basic controller).
- *heatcon! RC 130* room station at every heating circuit.
- Expandable with *heatapp!* wireless single room control for up to 24 rooms.

3.3 System overview

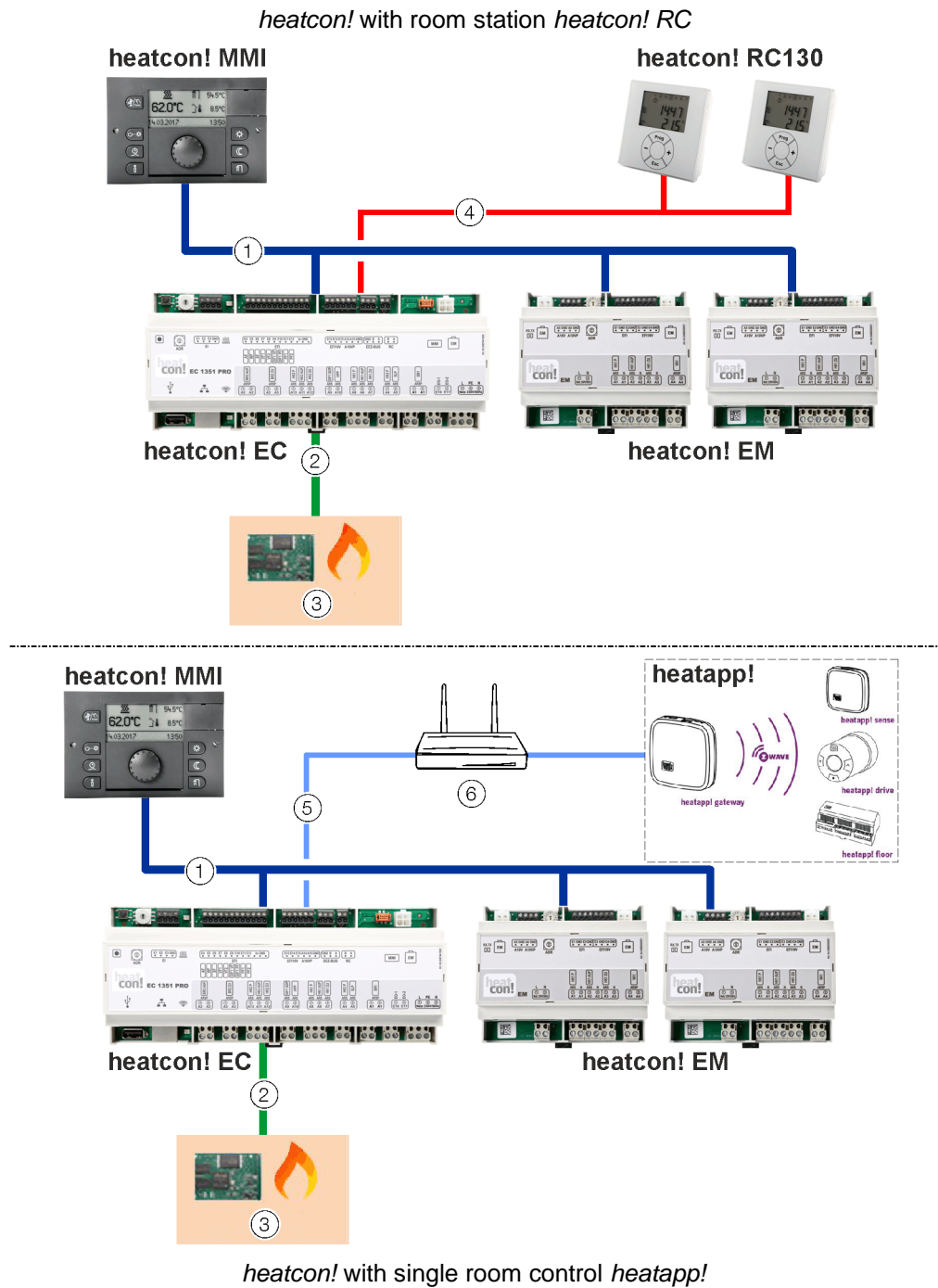

Fig. 1: heatcon! system overview

1	EbV system bus	4	EbV-Device bus
2	GEN-Bus (energy generator)	5	Network connection (Ethernet)
3	Energy generator	6	Router

4 Components

4.1 heatcon! MMI



Fig. 2: heatcon! MMI

1	Button "Emission measurement / manual mode" button	6	Button "Comfort/Economy temperature"
2	Button "Scenes/operating modes"	7	Button "Set-back temperature"
3	Button "Programming"	8	Button "Hot water daytime temperature"
4	Button "Info"	9	Display
5	Cover service connection	10	Rotary button (press & turn)

The *heatcon! MMI* is the control unit for the *heatcon! System* for operation without an Internet browser.

The buttons are used to call the corresponding menus.

Navigation through the menus and setting of values is performed using the rotary knob.

For more information on operation, see chapter "Operation", on page 15.

At each *heatcon! EC* a *heatcon! MMI* can be connected.

The assignment is made directly to the desired *heatcon! EC*.

Connect to:	Adress of EC:	MMI-No.:	Operation at:
EC 1	ADR 0	MMI 1	heatcon-0
EC 2	ADR 1	MMI 2	heatcon-1
EC 3	ADR 2	MMI 3	heatcon-2

NOTE

Setup of the *heatcon! MMIs* must be carried out one after the other, as the address assignment in the bus system is automatic.

4.2 heatcon! EC

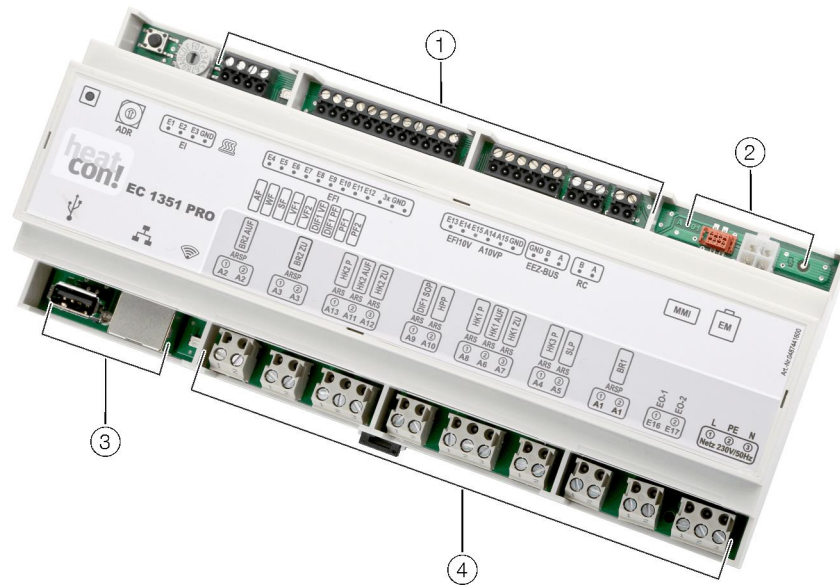

Fig. 3: heatcon! EC

1	Low voltage connections	3	USB/network connection
2	Data bus for system expansion	4	230V connections

The *heatcon! EC* is the main control unit and is installed in or on the energy generator.

This is where all components (pumps, valves, sensors) of the heating system are connected and controlled.

The energy generators are connected to the *heatcon! EC*.

For system expansion, further data bus connections are available.

heatcon! EC can be used as a mini cascade. With a heatcon! EC, two energy generators can be controlled and regulated in a cascade.

Expected from DEC 2018:

Addresses 0 ... 2 can be used with the rotary coding switch on heatcon! EC. This means that a maximum of 6 energy generators can be connected by using the mini cascade.

NOTE

Invalid addresses 3... 15 are interpreted as address setting 0!

EC 1	ADR 0
EC 2	ADR 1
EC 3	ADR 2

4.3 heatcon! EM

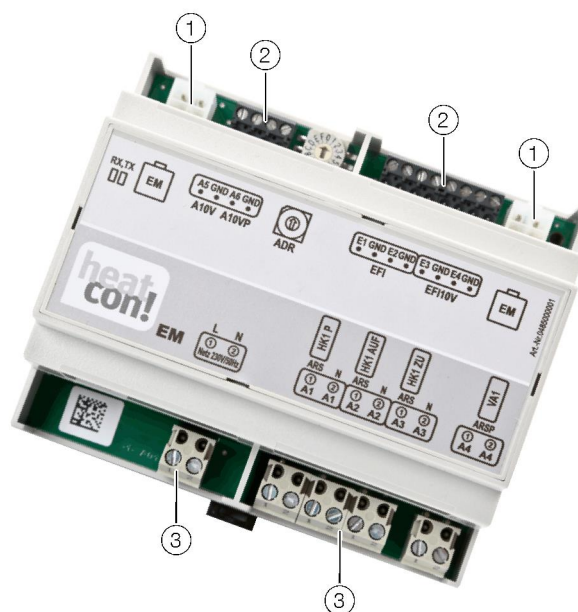

Fig. 4: heatcon! EM

1	EbV device bus	3	230V connections
2	Low voltage connections		

The *heatcon! EM* is an expansion for the inputs and outputs of a *heatcon! EC* inside the system.

Here other components (pumps, valves, sensors) of the heating system are connected and controlled.

The *heatcon! EM* is connected via the EbV-device bus with the *heatcon! EC*. Up to eight *heatcon! EM* can be connected to the *heatcon!*-System (maximum two expansion modules per *heatcon! EC* basic controller).

Addresses 0 ... 5 can be used with the rotary coding switch on *heatcon! EM*. This allows e.g. 6 additional heating circuits to be connected. A maximum of 15 heating circuits are possible in the system.

NOTE

The addresses 6 15 are without function!

The address settings on EM have the following default functions:

Connect to:	Adress of EC:	EM1-No.:	Adress EM:	Function
EC 1	ADR 0	EM1-A	ADR 0	heating circuit expansion 4 on EC 1
EC 1	ADR 0	EM1-B	ADR 1	heating circuit expansion 5 on EC 1
EC 2	ADR 1	EM1-A	ADR 2	heating circuit expansion 4 on EC 2
EC 2	ADR 1	EM1-B	ADR 3	heating circuit expansion 5 on EC 2
EC 3	ADR 2	EM1-A	ADR 4	heating circuit expansion 4 on EC 3
EC 3	ADR 2	EM1-B	ADR 5	heating circuit expansion 5 on EC 3

4.4 heatcon! RC 130



Fig. 5: heatcon! RC 130

RC130 serves as a living room remote control with room temperature recording for the heatcon! system. The temporary desired temperature can be set with the + or - button. RC 130 is integrated into the heatcon! system by addressing and assigned to a room group (1 of max. 5) or, with individual room control, a room (1 of max. 24).

The *heatcon! RC 130* is connected via a 2-wire bus with the *heatcon! EC*. Each room group in the system a heatcon! RC 130 can be assigned.

The assignment of the RC130 to the active heating zones (room groups):

Connect to:	Adress of EC:	RC130-No.:	Adress on RC130:
EC 1	ADR0	1	EC01 RC01
EC 1	ADR0	2	EC01 RC02
EC 1	ADR0	3	EC01 RC03
EC 1	ADR0	4	EC01 RC04
EC 1	ADR0	5	EC01 RC05
EC 2	ADR1	6	EC02 RC01
EC 2	ADR1	7	EC02 RC02
EC 2	ADR1	8	EC02 RC03
EC 2	ADR1	9	EC02 RC04
EC 2	ADR1	10	EC03 RC05
EC 3	ADR2	11	EC03 RC01
EC 3	ADR2	12	EC03 RC02
EC 3	ADR2	13	EC03 RC03
EC 3	ADR2	14	EC03 RC04
EC 3	ADR2	15	EC03 RC05

4.5 Single room control heatapp!



Fig. 6: *heatapp!*

The *heatcon!*-System can be expanded with the wireless single room control *heatapp!* to provide single room control for up to 24 rooms.

To do so, the *heatapp! gateway* must be connected via the Ethernet interface with the *heatcon! EC*.

Operation is via a tablet or smartphone using the *heatapp!-App*.

For more information about the *heatapp!*-System see www.heatapp.de.

5 Operation

5.1 heatcon! MMI

5.1.1 Basic display

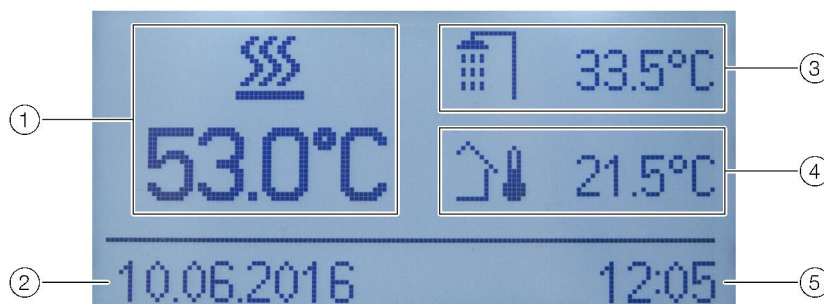

Fig. 7: heatcon! MMI — Basic display

1	Energy generator temperature	4	Outside Temperature
2	Date	5	Time
3	Hot water temperature		

After switching on the power supply, the basic display of the *heatcon! MMI* is displayed.

The following temperatures are displayed in the factory:

Energy generator - temperature

Hot water temperature

Outside Temperature



The temperatures shown in the basic display can be adjusted, see chapter "Configuring the basic display", on page 19.

5.1.2 Menu navigation

Operation takes place via the rotary button and the menu buttons on the *heatcon! MMI*.

Rotary button

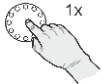
The rotary button is used to navigate through the menus and change parameters and values.

Action		Description
Rotation		Navigation through the menus. Setting of parameters and values.
Brief press (1x)		Selecting menus and parameters. Confirmation of parameter inputs.
Long press (>3s)		Calling the main menu.

Tab. 1: Rotary button functions

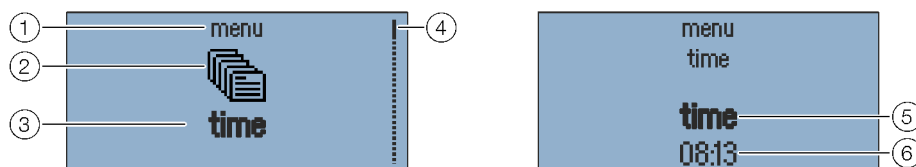

Fig. 8: Menu and parameter display

1	Menu level	4	Scrollbar
2	Menu symbol	5	Parameter
3	Submenu	6	Current value

Selecting and changing of menus and parameters

If the scroll bar is displayed in the menu, there are further selection options in the menu. These are navigated through by turning the rotary button.

If menus/parameters are **highlighted in bold**, they can be selected by pressing the rotary button.

To change parameters, select the parameters **highlighted in bold** by pressing the rotary button to edit them.

Now the value of the parameter is **highlighted in bold** and can be changed by turning the rotary button.







Press the rotary knob to save the setting.

Function of the Info button

The info button has a special function in menus. Pressing the info button moves backwards through menu levels.

Speed buttons

Functions are activated/deactivated via the speed buttons. Certain menus can be called directly to quickly change values.

Button	Description
	<p>Quick press: Start emission measurement.</p> <p>Long press (about 5 seconds): Energy generators manual mode activation. See chapter "Emission Measurement" on page 20.</p>
	<p>Calls the menu "<i>Scenes and operating modes</i>". See chapter "Operating modes and scenes" on page 22.</p>
	<p>Calls the menu "<i>Programming</i>". See chapter "<i>Programming</i>" on page 24.</p>
	<p>Calls the menu "<i>Information</i>". See chapter "Information level" on page 26.</p>
	<p>Calls the menu "<i>Comfort and Economy Temperature</i>". See chapter "Comfort and economy temperature" on page 27.</p>
	<p>Calls the menu "<i>Set-back Temperature</i>". See chapter "Set-back temperature" on page 28.</p>
	<p>Calls the menu "<i>Hot Water</i>". See chapter "Hot water" on page 29.</p>

Tab. 2: Button Functions

5.1.3 Menu overview

NOTE

The scope of the displayed menus and parameters depends on the system configuration and may differ from the diagram.

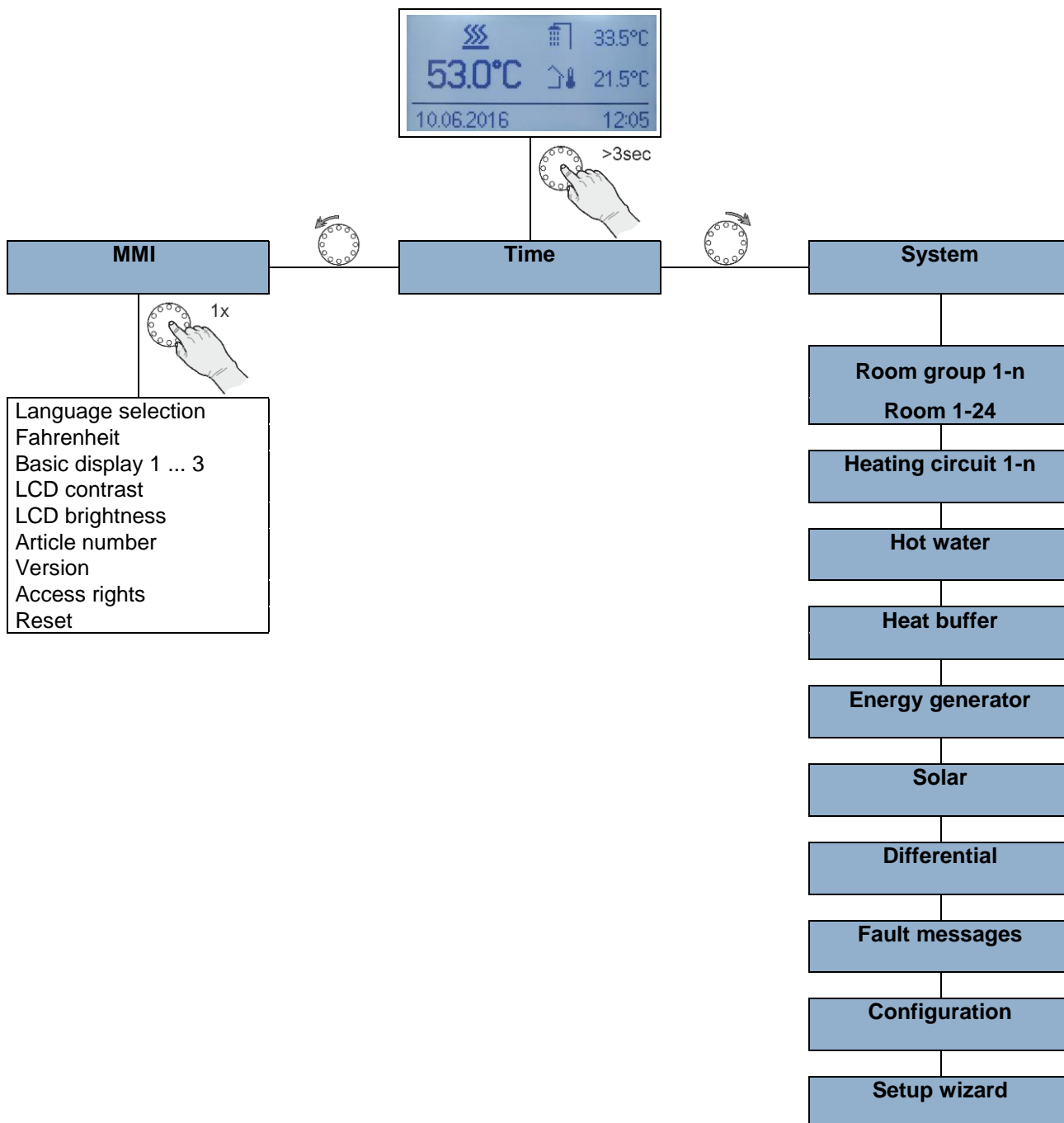

5.1.4 Configuring the basic display

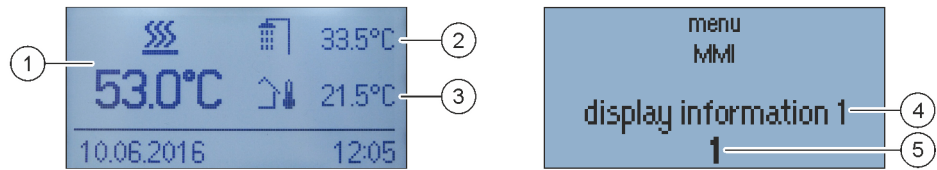

Fig. 9: heatcon! MMI — Configuring the basic display

1	Basic Display Position 1	4	Selected position of the basic display
2	Basic Display Position 2	5	Temperature selection 1...15
3	Basic Display Position 3		

The temperatures shown in the basic display can be selected via the MMI menu. The basic display has three display positions that can be filled with 15 different temperatures.

Examples are given in the following table:

Selection	Symbol	Description
OFF	—	No display.
1		Energy generator - temperature.
2		Hot water temperature.
3		Outside temperature.
4		Flow temperature heating circuit 1
5		Flow temperature heating circuit 2
6		Flow temperature heating circuit 3 (only modulating pump with FS)
7		Heating buffer temperature
8		Cooling buffer temperature (not used)
9, 10, 11		Flow temperature differential controller 1...3
12		Common flow temperature
13		Return temperature
14		Thermostat switching state
15	—	Not used

Tab. 3: Selection options

5.1.5 Speed button functions

5.1.5.1 Emission Measurement

⚠ CAUTION

Risk of scalding!

Risk of scalding during activated emission measurement by heating of the hot water above 60°C.

- Only qualified personnel may activate the “*Emission Measurement*” function.
- Before activating the “*Emission Measurement*” function, inform the users of the hot water system of the risk of scalding.
- When using hot water taps, mix in sufficient cold water.

If emission measurement is activated, the heat generator runs for 20 minutes at the maximum temperature limit set for the heat generator. The remaining time is displayed as it passes.

Both stages of two-stage heat generators are in operation (measurement with nominal capacity).

All heating circuits and DHW heating adjust their nominal value to the corresponding maximum temperature.

Activating:

To activate emission measurement, press the Emission measurement/manual mode" button.

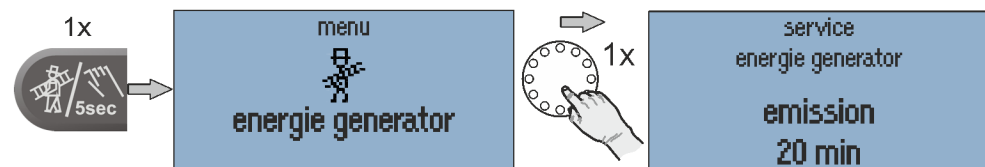

Fig. 10: Emission Measurement

Deactivating:

To deactivate emission measurement, press the Emission measurement/manual mode" button again.

5.1.5.2 Manual mode

If manual mode is activated, the required heat generator temperature is set manually with the rotary button according to the relevant heat demand (does not have any effect if operated as a heating circuit expansion).

All the pumps are active, while the available mixing valves are de-energized and can be actuated by hand if required for the heat demand.

Activating:

1. To activate manual mode, press the "Emission measurement/manual mode" button for 5 seconds and then release.
2. Set the desired temperature of the energy generator using the rotary wheel. The setpoint is adjustable between the minimum and maximum temperature of the energy generator.
3. If necessary, manually adjust the mixers present in the heating circuits.

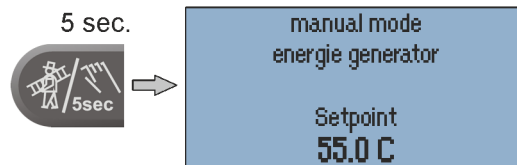

Fig. 11: Manual mode

Deactivating:

To deactivate manual mode measurement, briefly press the Emission measurement/manual mode button.

NOTE

- The heat generator maximum temperature limit takes priority over the heat generator switching differential and deactivates the heat generator if it is exceeded.
- The switching differential corresponds to the set switching differential for automatic control and is symmetrical to the setpoint temperature.
- With controllers that are operated purely as an expansion of the heating circuits, setting the temperature has no effect.
- The last value appears as a suggested value after the controller has adjusted to the heat generator temperature.

5.1.5.3 Operating modes and scenes

The operating mode can be set for the individual room groups (heating circuits), the hot water heating or for the entire system in the menu "Scenes/operating modes".

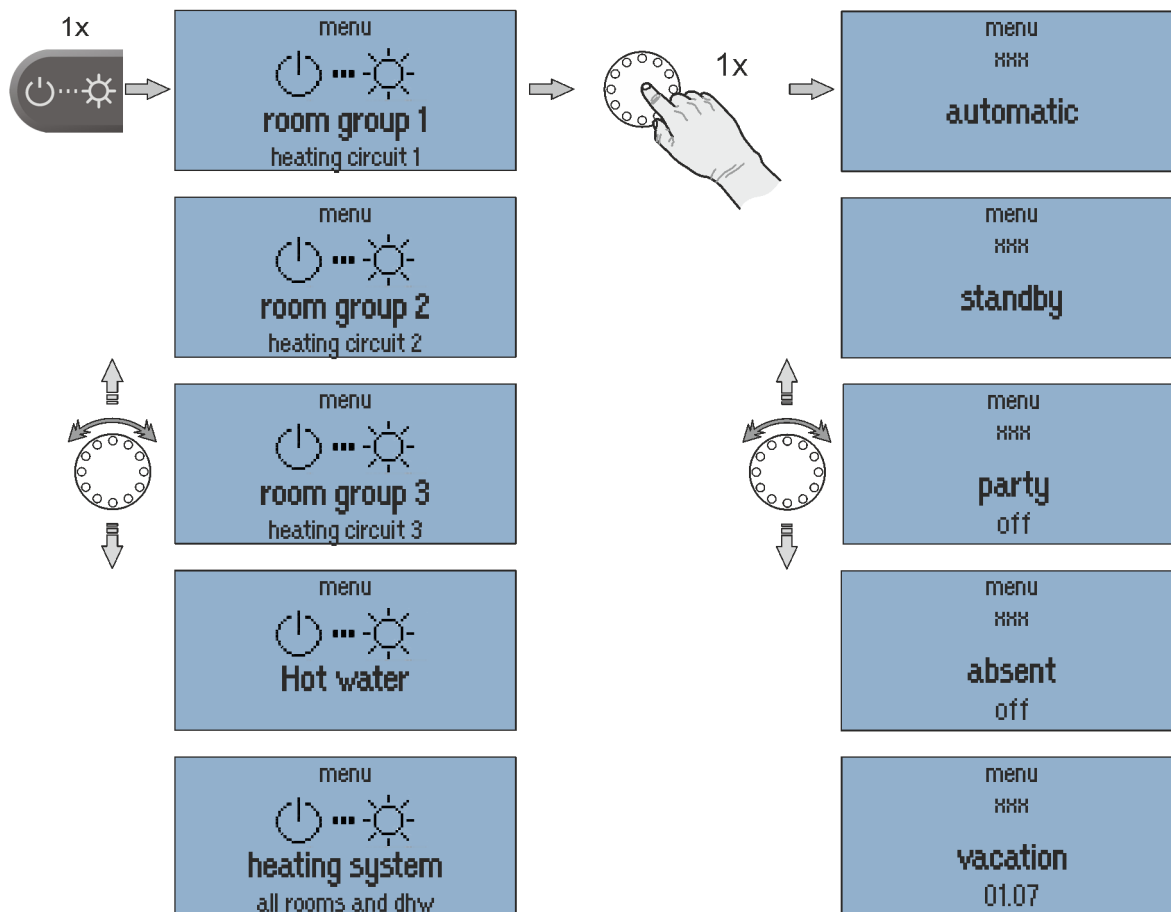

Fig. 12: Operation modes

Operation mode	Description
Automatic	Automatic mode for the selected heating circuit.
Standby	Operating mode " <i>Standby</i> " sets the room setpoint in the allocated rooms to the set frost protection temperature. In contrast to the vacation scene, the Standby function has no time limit. If the Standby function is activated for all the rooms/room groups, hot water heating is also switched off subject to frost protection.
Party	"Party" operating mode enables the overriding of the set cycle times for the rooms concerned. As long as "Party" operating mode is active, the corresponding comfort temperature applies for the rooms concerned. The operating mode is deactivated after the set runtime elapses. Setting range: Off ... + 12 h in steps of 0.5 h
Absent	"Absent" operating mode enables the overriding of the set cycle times for the rooms concerned. As long as the " <i>Absent</i> " operating mode is active, the corresponding set-back temperature applies for the rooms concerned. The scene is deactivated after the set runtime elapses. Setting range: Off ... + 12 h in steps of 0.5 h
Vacation	The "Vacation" operating mode is used to set the vacation duration in days. To do so, the vacation duration is entered from the current day in the format DD MM YY (day, month, year) using the rotary wheel. Activation of the vacation function ensures that the temperature does not fall below the minimum temperature (frost protection) of the rooms. Hot water heating is deactivated for the duration of the operating mode. However a set Legionella protection scheme remains active. Setting range: Day/Month/Year adjustable.
Magic wand (Only for operation via heatapp! App)	In " <i>Magic Wand</i> " operating mode the desired temperature has been set via the rotary wheel in the <i>heatapp! App</i> . The change to the desired temperature is only valid until the next programmed time change, at least for 3 hours.

Tab. 4: Operation modes

Note:

Summer operation:

For summer operation (hot water only), the room groups (heating circuits) must be set to "Standby" mode, while the hot water circuit is set to "Automatic".

If the assignment of the requirement to room was set in the hot water - basic setting menu, the hot water requirement is linked to the room groups. This means that if all room groups are switched off (standby or on holiday), the hot water circuit also switches off frost-protected.

5.1.5.4 Programming

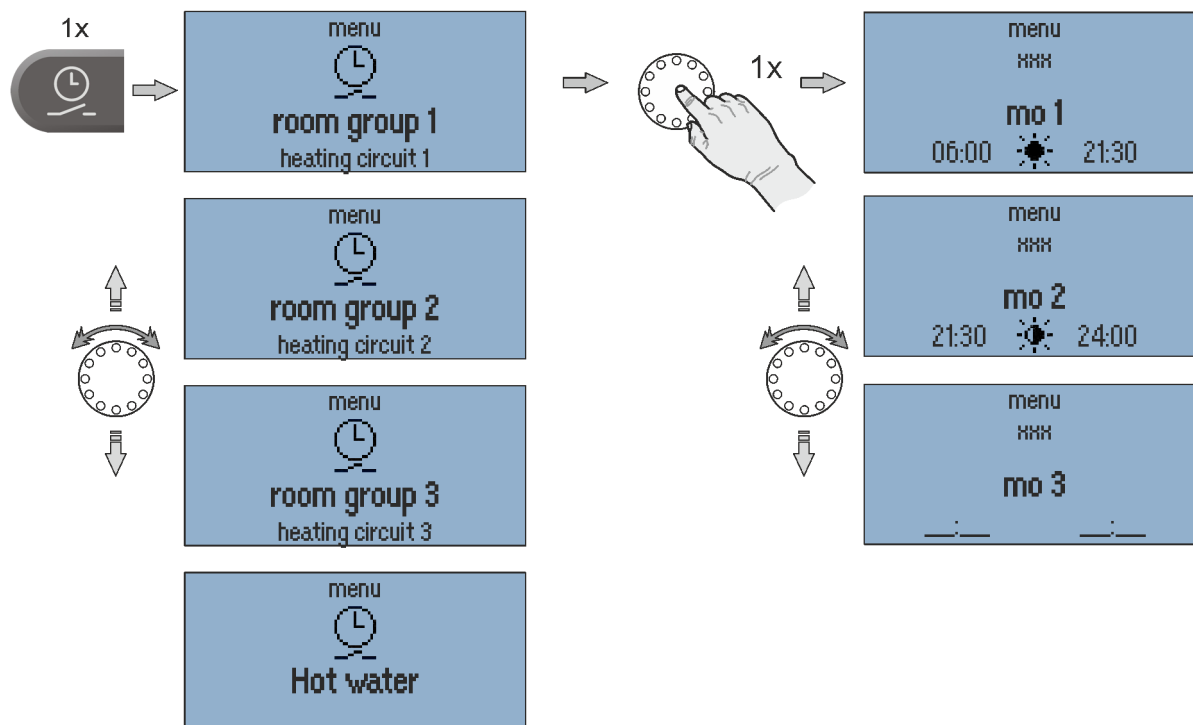

Fig. 13: Programming

In the "Programming" menu, individual switching cycles can be programmed for each room group (heating circuit) and the hot water.

For programming the switching times a maximum of three switching cycles, each with a switch-on and switch-off time, are available for each weekday. A choice can be made between comfort ☀ and economy temperatures 🌙.

Setting the switching time:

1. Select the desired room group/hot water.
2. Program the switching times for the day in question.
3. If necessary, select comfort ☀ and economy temperature 🌙.

NOTE

The default factory program is overwritten as individual switching times are programmed. The individual programming can be recorded in the tables in the appendix or backed up by creating a setup log file.

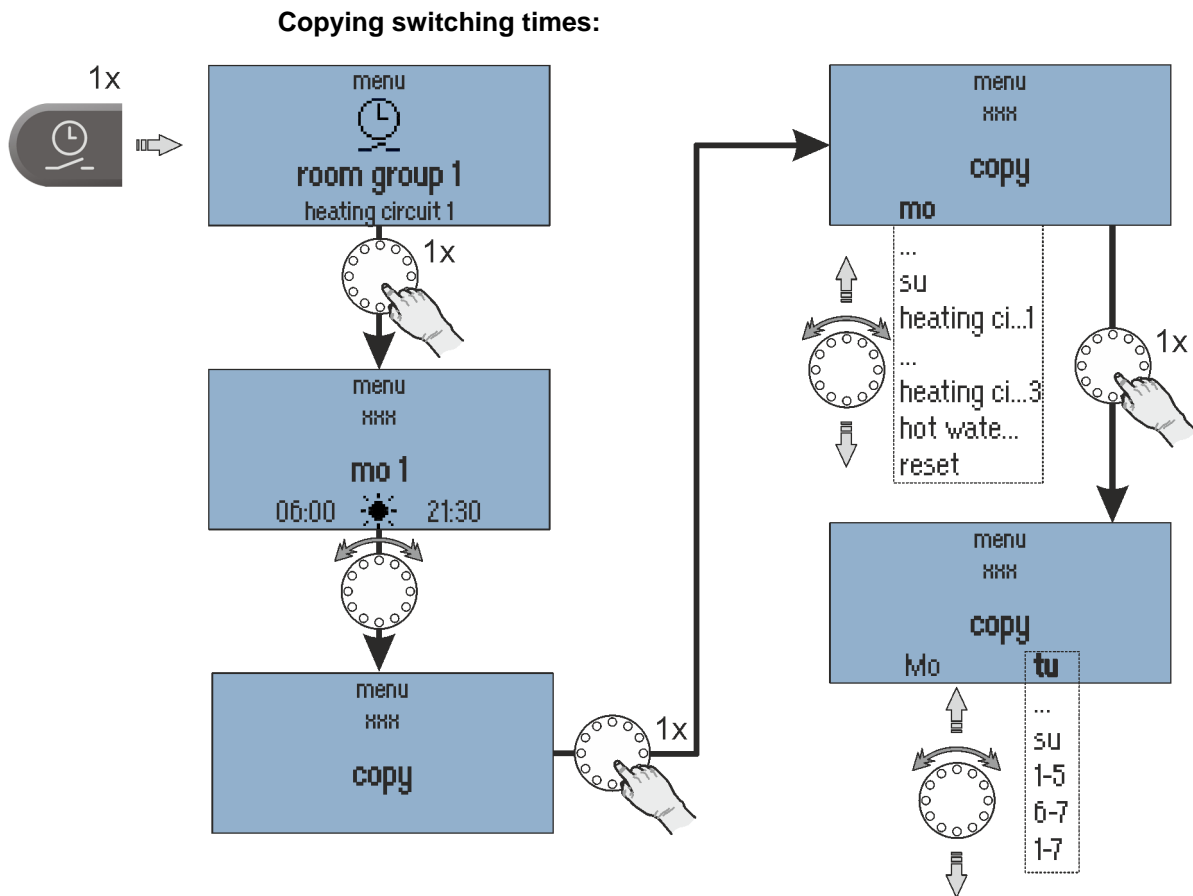

Fig. 14: Copying switching times

The switching cycles of a particular day or of heating circuit 1 ... n / hot water can be transferred to other days.

1. Select "Copy" submenu.
2. Select the desired source to copy.
3. Select the desired target day.

The source switching cycles are transferred to the desired target day.

Source/target	Description
Mo ... Su	Day Monday Sunday
Heat cir... 1...n	Switching cycles of heating circuit 1 ... n as source
Hot water...	Switching cycles, hot water as source
1-5	Monday to Friday as target
6-7	Saturday and Sunday as target
1-7	Monday to Sunday as target
Reset	Reset as the source resets the corresponding target to the factory default program.

Tab. 5: Available sources and targets

5.1.5.5 Information level

In the “*Information*” menu all available temperatures and system states can be displayed for each room group and each heating circuit.

With optional connection to the *heatapp!* single room control, the room temperatures of the individual rooms can also be displayed.

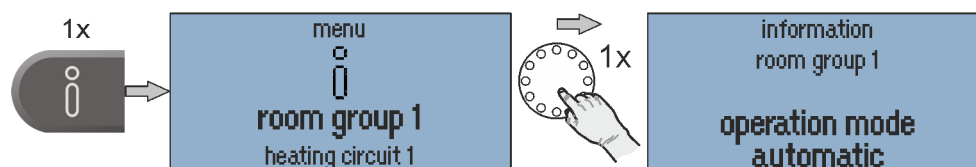

Fig. 15: Menu "Information"

NOTE

The "Information" menu is only used to display values. It cannot be used change values and parameters.

5.1.5.6 Comfort and economy temperature

The comfort and economy temperature are set for each room group and each heating circuit in the "Comfort/Economy Temperature" menu.

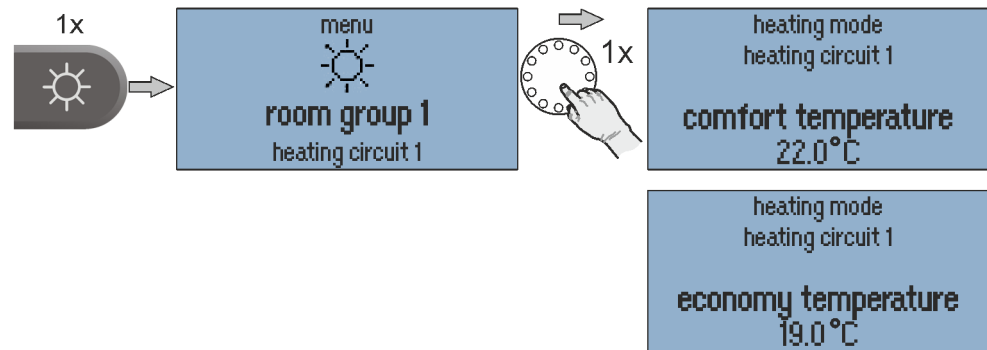

Fig. 16: Menu "Comfort/Economy Temperature"

Setting: the comfort/economy temperature:

1. Call menu "Day Temperatures".
2. Select the desired room group or system.
3. Set the desired comfort and economy temperature.

Factory preset		Setting range
Comfort temperature:	21 °C	Economy temperature ... 28 °C
Economy temperature:	20 °C	Set-back temperature ... Comfort temperature

Tab. 6: Factory presets

NOTE

Room group 1-n/Room 1-24: The set temperature is valid for the respective heating circuit or room.

System: The set temperature is valid for all heating circuits and rooms together.

The *comfort*, *economy* and *set-back* temperatures for all rooms or room groups as well as the hot water temperature (system) can only be set within the pre-set temperature limits:

- The *comfort temperature* not less than the *economy temperature*.
- The *economy temperature* not above the *comfort temperature* and not less than the *set-back temperature*.
- The *set-back temperature* not above the *economy temperature* and not less than the *frost protection temperature*.

The set temperature is the starting value for the individually adjustable temperature settings during the heating cycles (cycle temperatures) in the "Programming" menu.

5.1.5.7 Set-back temperature

The set-back temperature is set for each room group and each heating circuit in the "Set-back temperature" menu.

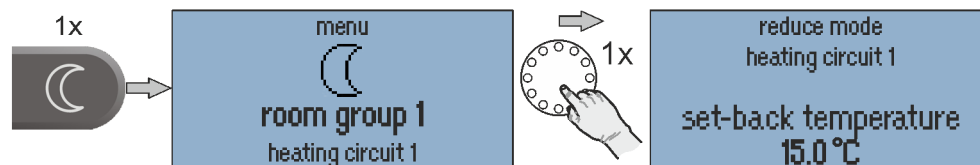

Fig. 17: Menu "Set-back temperature"

Set the set-back temperature:

1. Call menu "Set-back temperature".
2. Select the desired room group or system.
3. Set the desired set-back temperature.

Factory preset		Setting range
Set-back temperature:	18 °C	Frost protection temperature ... Economy temperature

Tab. 7: Factory presets

NOTE

Room group 1-n/Room 1-24: The set temperature is valid for the respective heating circuit or room.

System: The set temperature is valid for all heating circuits and rooms together.

The *comfort*, *economy* and *set-back temperatures* for all rooms or room groups as well as the hot water temperature (system) can only be set within the pre-set temperature limits:

- The *comfort temperature* not less than the *economy temperature*.
- The *economy temperature* not above the *comfort temperature* and not less than the *set-back temperature*.
- The *set-back temperature* not above the *economy temperature* and not less than the *frost protection temperature*.

The set temperature is the starting value for the individually adjustable temperature settings during the heating cycles (cycle temperatures) in the "Programming" menu.

5.1.5.8 Hot water

The hot water daytime temperature is set in the "Hot Water" menu.

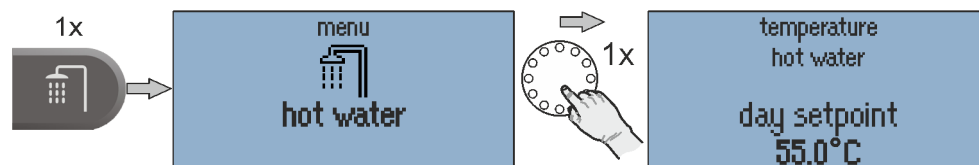

Fig. 18: Menu "Hot Water"

Setting the hot water daytime temperature:

1. Call menu "Hot Water".
2. Set the desired hot water daytime temperature.

Factory preset		Setting range
Hot water daytime temperature:	50 °C	5 °C ... Water heater maximum temperature limit

Tab. 8: Factory presets

NOTE

The set hot water daytime temperature is the starting value for the individually adjustable temperature settings applied during the standby cycles in the "Programming" menu.

6 Initial operation

6.1 Conditions and requirements

Prior to initial use of the controller, the following points must be fulfilled:

- The heating system must be made available in a fully complete state and filled with water to prevent damage to the pumps by dry running and to the energy generator by overheating.
- The controller must have been installed in compliance with the operating instructions.
- If an underfloor heating system is connected, then an additional limiting thermostat must be installed in the flow line downstream of the heating circuit pump to switch off the pump if the flow temperatures are too high.
- Prior to initial use of the controller all of the above requirements must be checked by a heating specialist.

6.2 Initial operation using the setup wizard

The system setup wizard is available: for the initial configuration of the *heatcon!* system:

- Setup wizard in *heatcon! MMI*, see chapter "Setup wizard in *heatcon! MMI*", on page 35.
- Setup wizard via PC / laptop / smartphone or tablet, see chapter "Setup wizard in the Internet browser on a PC/laptop", on page 38.

NOTE

During initial operation using the setup wizard, the assignment of the electrical inputs and outputs is performed according to the tables in the chapter "**Fehler! Verweisquelle konnte nicht gefunden werden.**", on page **Fehler! Textmarke nicht definiert.**

6.2.1 Assignment of the inputs and outputs

6.2.1.1 Overview

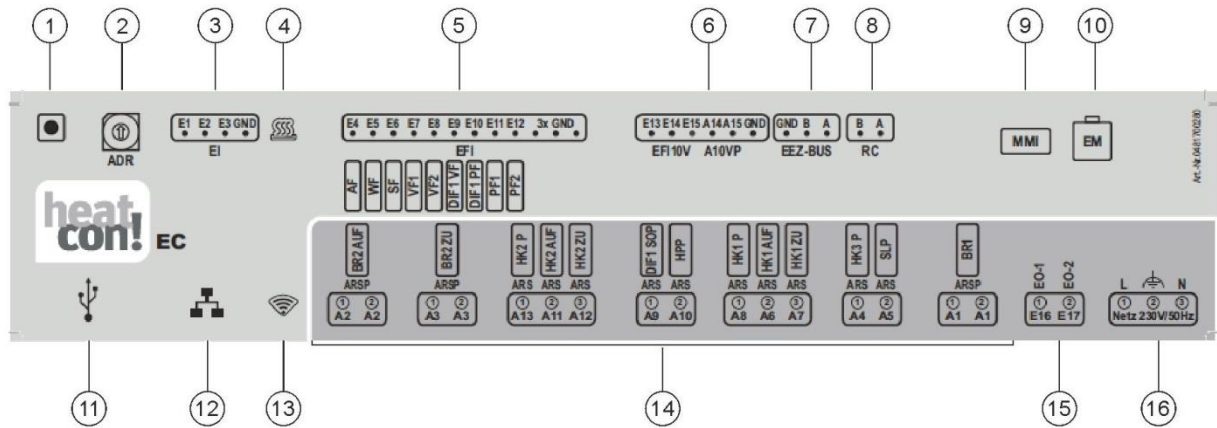

Fig. 19: heatcon! EC - connection assignment

1	Button	9	Connection <i>heatcon! MMI</i>
2	Address selector switch	10	EbV system bus for <i>heatcon! EM</i>
3	Digital inputs	11	USB connection
4	"Control" LED	12	Network connection (Ethernet, RJ45)
5	Temperature sensor inputs	13	"Network" LED
6	Analogue inputs/analogue outputs 0-10V	14	Digital outputs 230V AC
7	Energy generator bus	15	Digital inputs 230V AC
8	Two-wire bus h2B for room stations	16	Power supply

6.2.1.2 Energy generator

Individual setting	Configuration	Connections
Single-stage burner	Energy generator function ⇒ single-stage burner	A1 ⇒ BR1 E5 ⇒ WF
Two-stage burner	Energy generator function ⇒ two-stage burner	A1 ⇒ BR1 A2 ⇒ BR2 E5 ⇒ WF
Power Signal on/off	Energy generator function ⇒ modulating OFF/ON	A1 ⇒ BR1 A2 ⇒ BR2 AUF A3 ⇒ BR2 ZU E5 ⇒ WF
Control system (OT/Bus)	Energy generator function ⇒ Control system	EEZ-Bus A/B
Temperatur signal 0-10V	Energy generator function ⇒ Actuator signal 0-10V	A1 ⇒ BR A14 ⇒ A10VP E5 ⇒ WF
Release contact	Energy generator function ⇒ Switch contact	A1 ⇒ BR
Power signal 0-10V	Energy generator function ⇒ Modulating 0-10V	A1 ⇒ BR A14 ⇒ A10VP E5 ⇒ WF

Tab. 9: Standard connection assignment energy generator

6.2.1.3 Heating buffer

Individual setting	Configuration	Connections
Loading control	Heating buffer function ⇒ charging control	A10 ⇒ HPP E11 ⇒ PF1
Discharge control 1	Heating buffer function ⇒ Discharge control 1	E11 ⇒ PF1
Discharge control 2	Heating buffer function ⇒ Discharge control 2	E11 ⇒ PF1

Tab. 10: Standard connection assignment heating buffer

6.2.1.4 Hot water

Individual setting	Configuration	Connections
Storage charging pump	Hot water function ⇔ DHW storage charging pump	A5 ⇔ SLP E6 ⇔ SF
DHW circulation pump	Hot water function ⇔ DHW circulation pump.	A5 ⇔ ZKP E6 ⇔ SF
Burner control system (OT/Bus)	Hot water function ⇔ Control system	EEZ-Bus A/B
Heating usage	Hot water function ⇔ Heating usage	A5 ⇔ ELH E6 ⇔ SF

Tab. 11: Standard connection Hot water function

6.2.1.5 Heating circuit 1

Individual setting	Configuration	Connections
Unmixed circuit	Heating circuit 1 function ⇔ Pump	A8 ⇔ HK1P
Mixing circuit	Heating circuit 1 function ⇔ Valve	A8 ⇔ HK1P A6 ⇔ HK1AUF A7 ⇔ HK1ZU E7 ⇔ VF1

Tab. 12: Standard connection assignment heating circuit 1

6.2.1.6 Heating circuit 2

Individual setting	Configuration	Connections
Unmixed circuit	Heating circuit 2 function ⇔ Pump	A13 ⇔ HK2P
Mixing circuit	Heating circuit 2 function ⇔ Valve	A13 ⇔ HK2P A11 ⇔ HK2AUF A12 ⇔ HK2ZU E8 ⇔ VF2

Tab. 13: Standard connection assignment heating circuit 2

6.2.1.7 Heating circuit 3

Individual setting	Configuration	Connections
Unmixed circuit	Heating circuit 3 function ⇒ Pump	A4 ⇒ HK3P

Tab. 14: Standard connection assignment heating circuit 3

6.2.1.8 Differential 1

Individual setting	Configuration	Connections
Solar	Differential 1 function ⇒ Solar Flow sensor: E9:EFI DHW storage sensor: E10:EFI Pump relay: A9:ARS	A9 ⇒ SOP E9 ⇒ DIF1:VF E10 ⇒ DIF1:PF
Solid fuel	Differential 1 function ⇒ Solid fuel Flow sensor: E9:EFI DHW storage sensor: E10:EFI Pump relay: A9:ARS	A9 ⇒ FSP E9 ⇒ DIF1:VF E10 ⇒ DIF1:PF
Differential	Differential 1 function ⇒ Differential Flow sensor: E9:EFI DHW storage sensor: E10:EFI Pump relay: A9:ARS	A9 ⇒ DIF1P E9 ⇒ DIF1:VF E10 ⇒ DIF1:PF

Tab. 15: Standard connection differential controller

NOTE

As standard, temperature sensor input E9 is configured as the connection for PT1000 temperature sensors.

6.2.2 Setup wizard in heatcon! MMI

The setup wizard of the *heatcon!* system guides you in seven steps through the basic settings of the system.

NOTE

No access data are adjusted via *heatcon! MMI* nor are any network settings made. If operation is subsequently to take place via the *heatapp! App*, the first setup must be carried out using a PC/laptop.



Fig. 20: Start screen

After switching on the power supply, the setup wizard starts automatically in *heatcon! MMI*.

Press the rotary button to start the configuration.

Step 1: Languages

Setting options:

- DE = German
- GB = English
- FR = French
- IT = Italian
- NL = Dutsch
- PL = Polish
- ES = Spain
- TR = Turkish

Step 2: Selection of the energy generator function-1

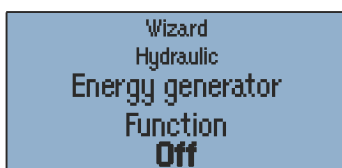

Select the energy generator function.

Setting options:

- Off
- Single-stage burner
- Two-stage burner
- Modulation Off/On
- Control system
- Actuator signal 0-10V
- Switch contact
- Modulation 0-10V

Fig. 21: Energy generator

Step 3: Selection of the energy generator function-2

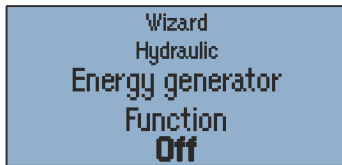

Fig. 22: Energy generator

Select the energy generator function.

Setting options:

- Off
- Single-stage burner
- Modulation Off/On
- Control system
- Actuator signal 0-10V
- Switch contact
- Modulation 0-10V

Step 4: Selection of the heating buffer function



Fig. 23: Heat buffer

Select the heating buffer (buffer storage) function.

Setting options:

- Off
- Loading control
- Discharge control 1
- Discharge control 2

Step 5: Selection of hot water heating

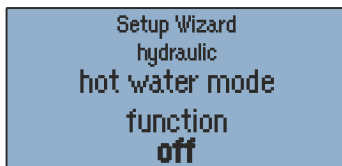

Fig. 24: Heat buffer

Select the hot water heating function.

Setting options:

- Off
- DHW storage charging pump
- DHW circulation pump
- Control system
- Heating usage

Step 6 to 8: Selection of the function for heating circuit 1...3

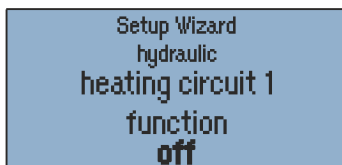

Fig. 25: Heating circuit 1...3

Select the function of heating circuits 1 ... n.

Setting options:

- Off
- Unmixed circuit
- Mixing circuit (only for HC 1 + 2)

NOTE

Only the actual hardware heating circuits are automatically displayed in the setup wizard.

For mixed heating circuits, configure heating circuits 1+2, heating circuit 3 can only be used as an unmixed circuit.

Step 9: Selection of the function for differential control



Select the differential control function.

Setting options:

- Off
- Solar
- Solid fuel
- Differential

Fig. 26: Differential control

Finished!

The initial setup of the *heatcon!* system is now complete. The system has created a room group for each configured heating circuit. All parameters and temperatures are set to the basic settings.

The assignment of the electrical inputs and outputs corresponds to the tables in chapter "Conditions and requirements", from page 30.

Further configuration takes place via the menu of *heatcon! MMI*, see chapter "Menu overview", on page 18.

6.2.3 Setup wizard in the Internet browser on a PC/laptop

6.2.4 Creating the network connection

The initial set-up of the *heatcon!* system is performed based on a menu control system via the set-up wizard on the Internet browser of the connected PC/laptop.

The connection can be made in two ways:

- Connection to the PC/laptop via Ethernet with the USB LAN adapter.
- Connection via Wi-Fi with the *heatapp! installation stick*. If using the *heatapp! installations stick*, the setup wizard can also be used with a tablet or smartphone.

NOTE

Automatic address allocation (DHCP) must be enabled in the network settings of the PC/laptop and no proxy server must be enabled.

1. Switch on the power supply for the *heatcon! EC*.
2. Connect the USB LAN adapter from the installation kit with the *heatcon! EC* and the network port on the PC/laptop:
 - Insert the USB LAN adapter in the USB port on the *heatcon! EC*.
 - Start the PC/laptop. Connect the **USB-LAN adapter** to the network port of the PC / laptop.

Alternatively:

2. Insert the *heatapp! installation stick* in the USB port on the *heatcon! EC*.
 - The *heatapp! installation stick* makes its own Wi-Fi network available (network name: *heatcon! EC*[xxxxxx]). The last 6 digits of the MAC ID (see also type plate of the *heatcon! EC*) are displayed in the square brackets.
 - Start the PC/laptop or tablet/smartphone. Connect the device to the wireless network "heatcon! EC[xxxxxx]".

Shortly thereafter, the set-up wizard starts automatically in the browser window of your device. If the set-up wizard does not start automatically, enter the address <http://10.0.0.1> in the address line of the Internet browser.

3. Follow the instructions in the setup wizard (see section "Performing the initial setup", from page 39).

6.2.4.1 Performing the initial setup

The setup wizard of the *heatcon!* system guides you in seven steps through the basic settings of the system.

Step 1 - Login

- Login as an expert to *heatcon! EC*.

NOTE

It is not necessary to login to the system for the initial configuration.

Step 2 - Network

For installation you require a functioning home network, an Internet connection is not necessary.

However, if you do not have an Internet connection you can only use *heatcon!* with your smartphone or tablet within your own home, not when you are under way.

Also you cannot load any updates for *heatcon!*. Therefore we strongly recommend connection of the *heatcon!* system to the Internet.

Login ✓ Network ✓ energy generator ✓ rooms ✓ name heating system ✓ user ✓ date / time ✓

Network

heatcon! ec has to be integrated into the network to allow access. Please chose your network connection.

- + network connection via LAN 192.168.1.2
- + network connection via WLAN
- + proxy server configuration 192.178.168.168

Internet access available

Apply network configuration

heatapp! connect

Would you like to operate the heating system from anywhere via Internet? Acitvate the connection to heatapp! connect.

yes connection to heatapp! connect

Connected successfully to heatapp! connect.

Fig. 27: Network configuration

Creating a network connection

- A LAN connection via DHCP is recommended (automatic setup of an Internet connection)
- LAN connection with manual settings (optional)
- Setup of a proxy connection (optional)

After an Internet connection has been created, the *heatcon!* system checks if an update is available.

- If a system update is available, an installation request appears. If the update is not installed, an initial setup cannot be performed.

NOTE

This step is omitted if no Internet connection is available.

- Connection to *heatapp! connect* for remote control of the *heatcon!* system. *heatapp! connect* is required so that the system can subsequently be operated via the app from any location.

Step 3 - Hydraulics



energy generator

1	energie generator 1 type single-stage burner name --	✓
2	energie generator 2 type single-stage burner name --	✓
3	heating buffer type charge control name --	✓
4	Domestic hot water Domestic hot water storage pumpe name --	✓
5	heating circuit valve 1 heating circuit 1 mixer circuit name --	✓
6	heating circuit valve 2 heating circuit 2 mixer circuit name --	✓
7	heating circuit 3 heating circuit 3 heating circuit name --	✓
8	differential control 1 Differential control type solar name --	✓
9	Single room heat regulation Single room heat regulation off	✓

Fig. 28: Hydraulic settings

The *heatcon!* system offers series of configuration models, the hydraulic schemes of which can be selected at this point. The other menu selections change depending on which selection is made on this page.

All available heating circuits are automatically displayed in the setup wizards.

- Configure the parameters according to the requirements of the heating system.

Selection of single room control

- Select whether the connection to the single room control *heatapp!* is available.

When "Off" is selected, the room groups of the *heatcon!* system are controlled by the *heatapp!* app.

Step 4 room groups and rooms

Network > energy generator > rooms > name heating system > user > date / time

rooms and roomgroups

Register the rooms for single room control, to be controlled with heatcon! Without single room control a room group for each heating circuit is displayed. The name displays the controlled rooms.

1 room 1 heating circuit 1 room name heating circuit 1 | room supply heating circuit 1

Here you can change the default name, which is used in the skilled area. Optionally, correct the supply room.

room name

room supply

Delete
back
save

2 room 2 heating circuit 2 room name heating circuit 2 | room supply heating circuit 2 ✓

3 Create a new heating zone +

Fig. 29: Room groups/rooms

Without single room control *heatapp!*:

A room group is created for each heating circuit. As with a single room control, all the data relevant to the room group such as temperatures, timer programs etc. can be individually adjusted for the room group and do not affect the entire system. The room group setting act immediately on the assigned heating circuit.

With single room control *heatapp!*:

Here you create all rooms that are to be regulated by *heatapp!* and assign the rooms to the room supply. The room supply controls at which point the requirement is created so that the room is supplied with the necessary heat.

Step 5 - My System

Network ✓ → energy generator ✓ → rooms ✓ → name heating system ✓ → user ✓ → date / time ✓

name heating system

Fill in here the name of your heating system. This name is shown later in the heatapp! app. As plant location please fill in the postcode name of your residence to display the weather data.

name heating system:

plant location:

Fig. 30: My system

Allocate a name to your *heatcon!* system and enter the location (town and postcode). The entered location is used to display the weather data in the *heatapp! App*.

Step 6 - Users

Network ✓ > energy generator ✓ > rooms ✓ > name heating system ✓ > user ✓ > date / time ✓

user

To use the heatcon! ec, the user must with username and password to login. Register at least two users who have the roles:

- Expert, for full access to all settings
- Owner, for individualisation and user management

Additional users can be added to at a later date.

Caution:

Without login credentials is the use of the heatcon! ec not possible!
Keep the data.

+ Please create a new user.	
1	admin Mr. Admin Admin user role: Expert
2	owner Mr. Owner Owner user role: owner
3	user Mr. User User user role: user

Please create a new user. ✕

user role: user name:

title: password:

first name: Repeat your password:

name:

Fig. 31: User administration

To be able to operate the *heatcon!* system, the users must login to the system with user name and password. Create at least two users with the following user roles:

- Expert for complete access to all settings
- Owner, for customisation and user management

Further users can be added at a later date.

ATTENTION

Use of the *heatcon!* system without access data is not possible either in the app or from a PC. Therefore keep the access data somewhere safe.

Creating users:**NOTE**

The user name must be at least 5 characters long. Allowed characters are upper case and lower case letters A-Z (a-z), special German characters äöüß, numbers 0-9 and special characters @-_.

The password must contain at least 5 characters from two of the following character groups: Lower case letters, upper case letters, special characters, numbers.

1. Select the user role.
2. Enter first and last name of the user.
3. Enter the user name.
4. Assign a password for the user.
5. Save the user by clicking on "*Create*".

Step 7- Date and time

Network > energy generator > rooms > name heating system > user > date / time

date / time

system time: 04.01.2018 11:44 (Europe/Berlin)

time zone:

time synchronisation

automatic Internet synchronisation

automatic time sync with your own NTP server.

manual time setting

Please enter the current time for the heatapp! base

Save time and day on this device.

date:

time:

save

Fig. 32: Date and time

Here you select the time zone for your location (town of residence).

You can select between the following variants:

- Time synchronisation via the Internet
- Time synchronisation via an internal NTP server
- Manual time setting

Finished!

The initial setup of the *heatcon!* system is now complete. All parameters and temperatures are set to the basic settings.

The assignment of the electrical inputs and outputs corresponds to the list in section "**Fehler! Verweisquelle konnte nicht gefunden werden.**", on page **Fehler! Textmarke nicht definiert.**

Further configuration takes place via the "Expert" menu.

6.2.4.2 Establishment protocol

In the "Establishment protocol" area, a establishment protocol can be generated and sent by e-mail. The establishment protocol contains all information of your heatcon! configuration.

Generate Establishment protocol

- Tap on the "Generate a new establishment protocol" button to create a protocol.

The establishment protocol is stored in the heatcon! EC until a new one is build. This allows you to access at the last establishment protocol at any time ("show establishment protocol" button) and/or send a PDF by e-mail ("Send establishment protocol" button).

Sending the establishment protocol by e-mail

1. Tap on the "Add a new e-mail address" button.
2. Enter the email address to which the establishment protocol is to be sent. You can enter multiple e-mail addresses.
3. Press the "Send establishment protocol" button to send the protocol.

If sending was successfull, a corresponding message is displayed.

Use the button  to return to the "System" menu.

6.3 Single room control heatapp!

If the selection "*Single room control - On*" was selected in the setup wizard, the *heatapp! gateway* and the *heatapp!* wireless components must now be set up. Setup takes place according to the installation instructions which are supplied with the *heatapp! gateway* or according to the online instructions of the *heatapp!* system under <https://heatapp.de/service/downloads/>.

7 Attachment

7.1 Switching times table

Room	DAY	Switching time 1	Switching time 2	Switching time 3
	Mo			
	Tu			
	We			
	Th			
	Fr			
	Sa			
	Su			
	Mo			
	Tu			
	We			
	Th			
	Fr			
	Sa			
	Su			
	Mo			
	Tu			
	We			
	Th			
	Fr			
	Sa			
	Su			
	Mo			
	Tu			
	We			
	Th			
	Fr			
	Sa			
	Su			
	Mo			
	Tu			
	We			
	Th			
	Fr			
	Sa			
	Su			
	Mo			
	Tu			
	We			
	Th			
	Fr			
	Sa			
	Su			

Tab. 16: Switching times table

7.2 Login data

Note the login data to your *heatcon!* system here:

User level	User name	Password
Expert:	<input type="text"/>	<input type="text"/>
Caretaker:	<input type="text"/>	<input type="text"/>

When connecting to the single room control *heatapp!* please record the password of the *heatapp!* gateway here:

heatapp! gateway	
Password:	<input type="text"/>

NOTE

Create a setup log file and a data backup after completing the installation.

8 Index

B		M	
Basic display	15	Manual mode	21
C		Menu navigation	16
Chimney sweep function	20	Menu overview	18
Comfort temperature	27	O	
Configuring the		Operation	10, 15
basic display	19	Operation mode	22
Creating users	45	P	
E		Programming	24
Economy temperature	27	R	
Emission Measurement	20	Rotary button	16
H		S	
heatcon! EC	11	Safety	4
heatcon! EM	12	Scenes	22
heatcon! MMI	10, 15	Set-back temperature	28
heatcon! RC 130	13	Setup wizard	
Hot water	29	heatcon! MMI	35
I		Internetbrowser	38
Info button	17	PC/Laptop	38
Information level	26	Single room control heatapp! ..	14, 48
Initial operation	30	Speed buttons	17
L		Functions	20
Login data	50	Switching times table	49
		System description	5, 8
		System expansion	8